

HP F1477A Docking System

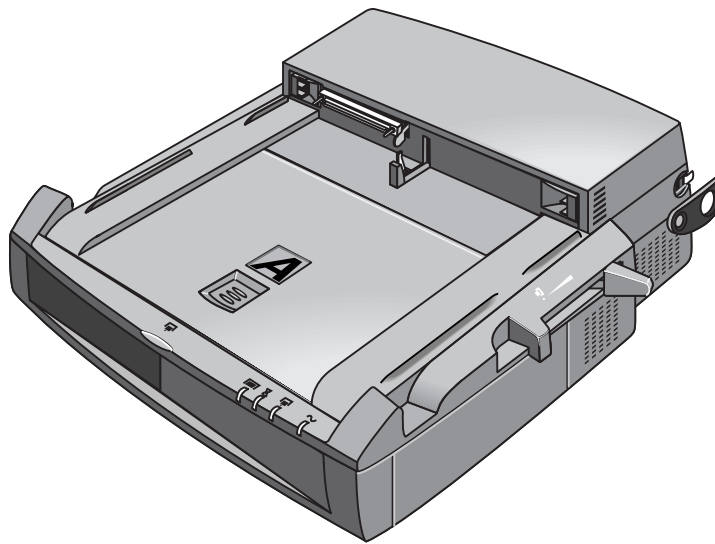

Service Manual

Notice

In a continuing effort to improve the quality of our products, technical and environmental information in this document is subject to change without notice.

This manual and any examples contained herein are provided “as is” and are subject to change without notice. Hewlett-Packard Company makes no warranty of any kind with regard to this manual, including, but not limited to, the implied warranties of merchantability and fitness for a particular purpose. Hewlett-Packard Co. shall not be liable for any errors or for incidental or consequential damages in connection with the furnishing, performance, or use of this manual or the examples herein.

Consumer transactions in Australia and the United Kingdom: The above disclaimers and limitations shall not apply to Consumer transactions in Australia and the United Kingdom and shall not affect the statutory rights of Consumers.

© Copyright Hewlett-Packard Company 1997, 1998. All rights reserved. Reproduction, adaptation, or translation of this manual is prohibited without prior written permission of Hewlett-Packard Company, except as allowed under the copyright laws.

The programs that control this product are copyrighted and all rights are reserved. Reproduction, adaptation, or translation of those programs without prior written permission of Hewlett-Packard Co. is also prohibited.

Portions of the programs that control this product may also be copyrighted by Microsoft Corporation, SystemSoft Corp., Crystal Semiconductor Corporation, Phoenix Technologies, Ltd., and NeoMagic, Inc. See the individual programs for additional copyright notices.

Microsoft, MS, MS-DOS, and Windows are registered trademarks of Microsoft Corporation. Pentium and the Intel Inside logo are U.S. registered trademarks and MMX is a U.S. trademark of Intel Corporation.

All certifications may not be completed at product introduction. Check with your HP reseller for certification status.

This equipment is subject to FCC rules. It will comply with the appropriate FCC rules before final delivery to the buyer.

Hewlett-Packard Company
Mobile Computing Division
19310 Pruneridge Ave.
Cupertino, CA 95014, U.S.A.

Edition History

Edition 1November 1998

Contents

1. Product Information	1-1
Features and Operation.....	1-2
To Set Up the Dock	1-3
To Dock the OmniBook.....	1-4
To Undock the OmniBook.....	1-6
To Manually Undock the OmniBook	1-7
To Turn the OmniBook On and Off	1-8
Specifications.....	1-9
Internal Design.....	1-10
2. Removal and Replacement	2-1
Removing the Tray (User-Replaceable).....	2-2
Opening the Top Cover (User-Replaceable)	2-3
Removing the Cable Protection Shield (HP Authorized Service Providers Only).....	2-5
Removing the IDE and SCSI Cables (User-replaceable)	2-6
Removing the Audio Cables (User-replaceable).....	2-7
Removing the PCI Cable (HP Authorized Service Providers Only)	2-8
Removing the PC Module Housing (User-Replaceable).....	2-9
Removing the PCI Door (User Replaceable).....	2-11
Removing the PCI Housing (HP Authorized Service Providers Only).....	2-12
Removing the PCI Backplane (HP Authorized Service Providers Only).....	2-14
Removing the PCI Fan (HP Authorized Service Providers Only).....	2-15
Removing the Module Bay Adapter (User-Replaceable).....	2-16
Removing the Module Bay Adapter Housing (HP Authorized Service Providers Only).....	2-17
Removing the Power Supply (HP Authorized Service Providers Only).....	2-18
Removing the Solenoid (HP Authorized Service Providers Only).....	2-19
Removing the LED/Button Assembly (HP Authorized Service Providers Only).....	2-20
Removing the Release Lever (HP Authorized Service Providers Only).....	2-21
Removing the Electronics Module Cover (HP Authorized Service Providers Only).....	2-22
Removing the Electronics Module (HP Authorized Service Providers Only).....	2-23
Opening the Electronics Module (HP Authorized Service Providers Only).....	2-24
Removing the Electronics PCA (HP Authorized Service Providers Only).....	2-25
Removing a PCMCIA Socket (HP Authorized Service Providers Only).....	2-26
Removing the Module Bay and PC Device Slot Covers (User Replaceable).....	2-27
Removing the Front Bezel (HP Authorized Service Providers Only).....	2-28
Removing the Rear Bezel (HP Authorized Service Providers Only).....	2-29
3. Troubleshooting and Diagnostics.....	3-1
Troubleshooting	3-2
Troubleshooting the Problem.....	3-3
Verifying the Repair	3-3
Suggestions for Troubleshooting	3-4
Diagnostic Tools.....	3-8
OmniBook Diagnostic Program.....	3-8
BIOS Setup Utility.....	3-9
4. Replaceable Parts	4-1

Figures

Figure 1-1. Docking System - Rear View	1-2
Figure 1-2. Docking System - Front View	1-2
Figure 1-3. Plugging in the Dock	1-3
Figure 1-4. Attaching the Security Post	1-3
Figure 1-5. Inserting the Tray in the Dock	1-4
Figure 1-6. Opening the Rear Port Door	1-4
Figure 1-7. Placing the OmniBook on the Dock Tray	1-5
Figure 1-8. Docking the OmniBook	1-5
Figure 1-9. Dock Undock Button and LEDs	1-6
Figure 1-10. Ejecting the OmniBook from the Dock	1-6
Figure 1-11. Manually Undocking the OmniBook	1-7
Figure 1-12. Turning the OmniBook On and Off	1-8
Figure 1-13. Replaceable Module Diagram	1-10
Figure 2-1. Removing the Tray	2-2
Figure 2-2. Removing the Top Cover Screws	2-3
Figure 2-3. Sliding the Top Cover Back	2-3
Figure 2-4. Folding the Top Cover Back	2-4
Figure 2-5. Removing the Cable Protection Shield	2-5
Figure 2-6. Removing the IDE and SCSI Cables	2-6
Figure 2-7. Removing the Audio Cables	2-7
Figure 2-8. Removing the PC Module Housing	2-8
Figure 2-9. Removing the 3 1/2 Inch Adapter Kit or 5 1/4 Inch Device	2-9
Figure 2-10. Removing a 3 1/2 Inch Device	2-10
Figure 2-11. Removing the PCI Door	2-11
Figure 2-12. Removing the PCI Housing	2-13
Figure 2-13. Removing the PCI Backplane	2-14
Figure 2-14. Removing the PCI Fan	2-15
Figure 2-15. Removing the Module Bay Adapter	2-15
Figure 2-16. Removing the Module Bay Adapter Housing	2-17
Figure 2-17. Removing the Power Supply	2-17
Figure 2-18. Removing the Solenoid	2-19
Figure 2-19. Removing the LED/Button Assembly	2-20
Figure 2-20. Removing the Release Lever	2-21
Figure 2-21. Removing the Electronics Module Cover	2-21
Figure 2-22. Removing the Electronics Module	2-23
Figure 2-23. Opening the Electronics Module	2-24
Figure 2-24. Removing the Electronics PCA	2-25
Figure 2-25. Removing a PCMCIA Socket	2-26
Figure 2-26. Removing the Module Bay and PC Device Slot Covers	2-27
Figure 2-27. Removing the Front Bezel	2-28
Figure 2-28. Removing the Rear Bezel	2-29
Figure 3-1. Basic Troubleshooting Steps	3-2
Figure 4-1. Exploded View	4-2

Tables

Table 1-1. Docking System Specifications.....	1-9
Table 1-2. Module Components/Functions	1-11
Table 2-1. Removal Cross-Reference.....	2-1
Table 2-2. Required Equipment.....	2-1
Table 3-1. Troubleshooting Suggestions.....	3-4
Table 3-2. Docking System Diagnostic Error Codes.....	3-9
Table 4-1. Docking System Replaceable Parts.....	4-3
Table 4-2. Docking System Power Cables.....	4-4
Table 4-3. Docking System Accessories	4-4

Introduction

This service manual provides reference information for the F1477A docking system. It is intended to be used by HP-authorized service personnel in the installation, servicing, and repair of this product.

This manual is designed as a self-paced guide. It is intended to train you to install and repair the docking system. You can follow this manual without having equipment available.

The following table lists additional places where you can get supplementary information about the docking system and other HP OmniBook products.

Sources of OmniBook Information

Source	Address or Number	Comments
HP External Web	http://www.hp.com/omnibook (http://www.europe.hp.com/omnibook , European mirror)	No usage restriction.
HP US Reseller Web	http://partner.americas.hp.com	Restricted to Authorized Resellers only.
HP Asia Pacific Channel Support Centre for DPSP Partners	http://www.hp.com.au	Restricted to DPSP Partners only.
America Online	Keyword: HP	Call (800) 827-6364 for membership within the US.
CompuServe	GO HP	Call (800) 524-3388 for membership within the US.
HP Bulletin Board Service		Refer to the latest Product Support Plan for non-US BBS numbers.
HP First (automated fax)	(800) 333-1917	US and Canada.
	(801) 344-4809	Outside US and Canada.
	(800) 544-9976	Reseller support number (enter outlet id number).
HP Support Assist CD-ROM	(800) 457-1762	US and Canada.
	(801) 431-1587	Outside US and Canada.

Product Information

The HP 1477A docking system (referred to as dock in this manual), significantly increases the convenience of the HP OmniBook for desktop use. Making one connection—plugging the OmniBook into the dock—provides easy access to these types of devices:

- Printer, external floppy drive, or other parallel device.
- Modem or other standard serial device.
- Universal serial bus (USB) devices.
- SCSI-2 and IDE devices.
- Type II and Type III CardBus devices
- Additional OmniBook plug-in modules.
- PCI accessory boards.
- PC expansion devices.
- External keyboard and external mouse.
- External monitor.
- Audio connections.

Features and Operation

The following two illustrations point out the main external features of the dock. They are followed by highlights of the dock's operation. For an internal, exploded view, see page 4-2.

1. Two type II or type III PC card slots (CardBus enabled)
2. PC card security lock
3. Mouse port
4. Keyboard port
5. Two universal serial bus (USB) ports
6. PCI board slots
7. SCSI-2 port
8. Serial port
9. Parallel port
10. AC power connector
11. Monitor port
12. Headphones or speaker-out
13. Microphone-in
14. Audio line-in
15. System-off button
16. Power/Suspend button

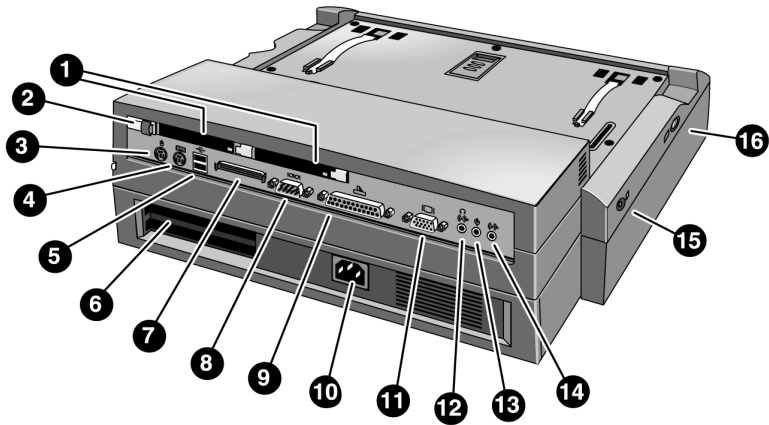

Figure 1-1. Docking System - Rear View

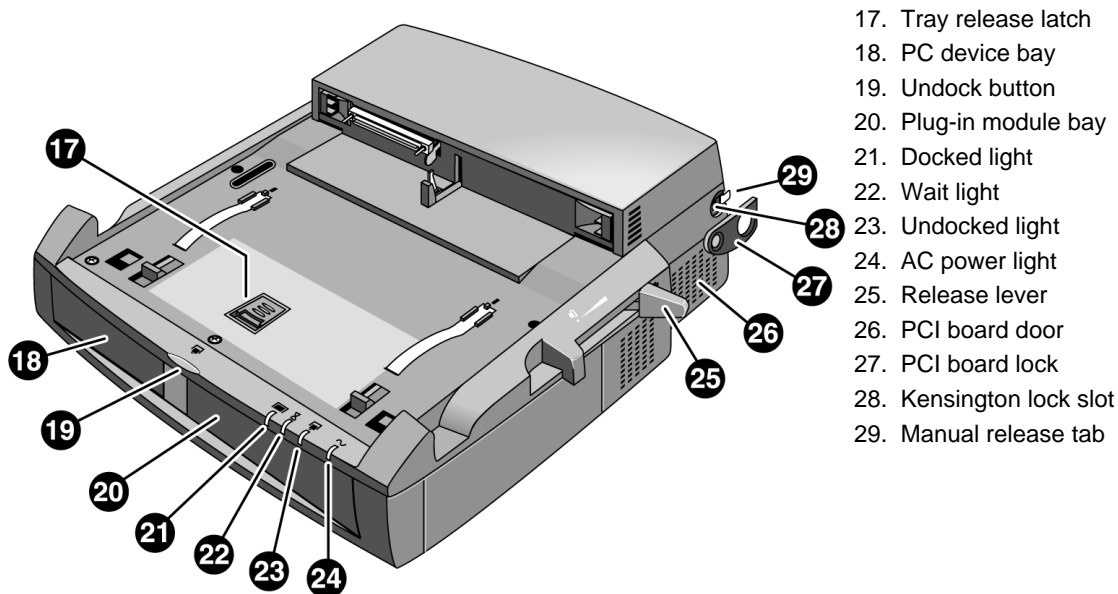

Figure 1-2. Docking System - Front View

To Set Up the Dock

1. Plug the power cord into the dock, then plug the power cord into the ac outlet.

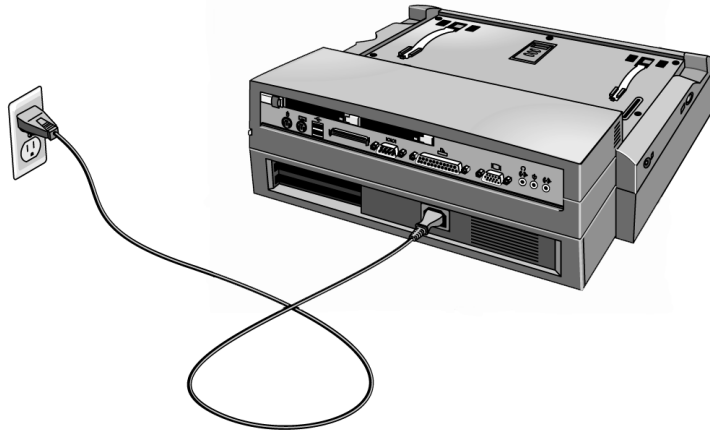

Figure 1-3. Plugging in the Dock

2. Select the appropriate dock tray for the OmniBook. Match the letter on the tray with the letter for the OmniBook listed on the dock label next to the tray release latch.
3. Attach the security post to the tray (optional). The security post prevents removal of the OmniBook PC cards. The security post on the tray may be in a different location from that shown below.

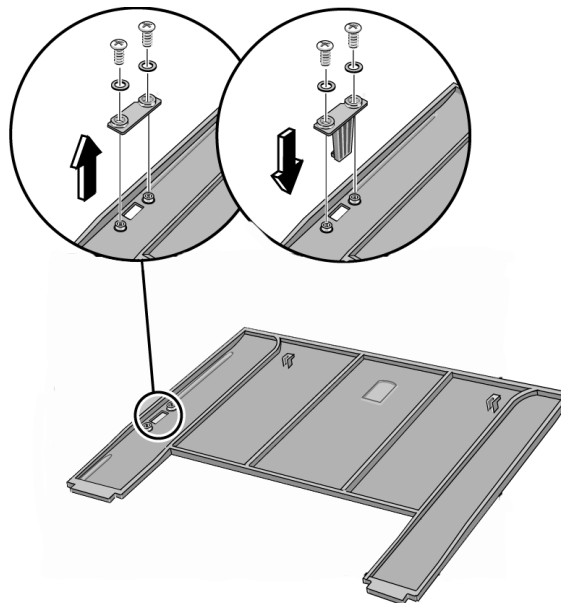

Figure 1-4. Attaching the Security Post

Caution

Use only the metalized dock trays provided with the docking system. Do NOT use the plastic dock trays provided with the F1451A Port Replicator and F1452A Mini Dock.

4. Insert the tabs on the back of the tray into the slots in the dock and press down on the front edge of the tray to lock it in place.

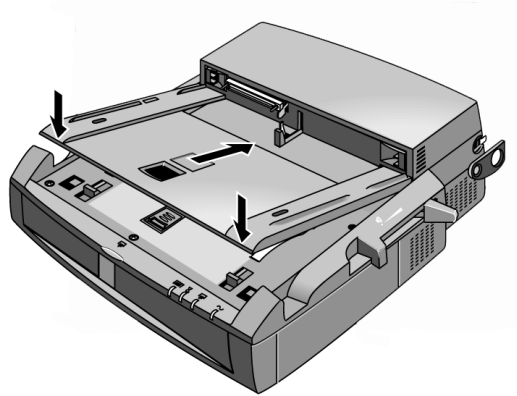

Figure 1-5. Inserting the Tray in the Dock

To Dock the OmniBook

1. Place the dock on a flat surface.
2. Slide the OmniBook's docking door to the left.

Some OmniBook models, including the OmniBook 4100 have a rear port door that opens automatically when you install it in the dock. Refer to the Reference Guide for the OmniBook to see if it has this feature.

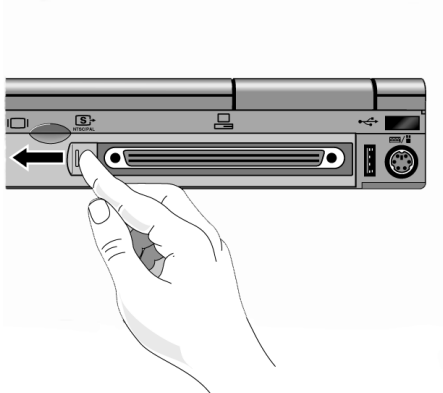

Figure 1-6. Opening the Rear Port Door

3. Place the OmniBook on the dock tray, with the back of the computer facing the dock's connector.

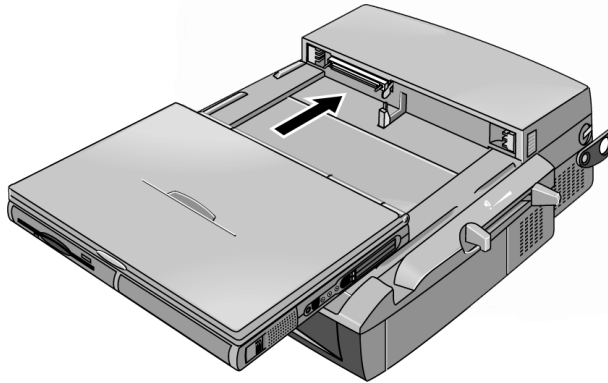

Figure 1-7. Placing the OmniBook on the Dock Tray

4. Position your fingers on the platform grips as shown below. Use your thumbs to push the computer firmly toward the dock until the OmniBook slides into place. You should hear a click, indicating that the OmniBook is locked to the dock.

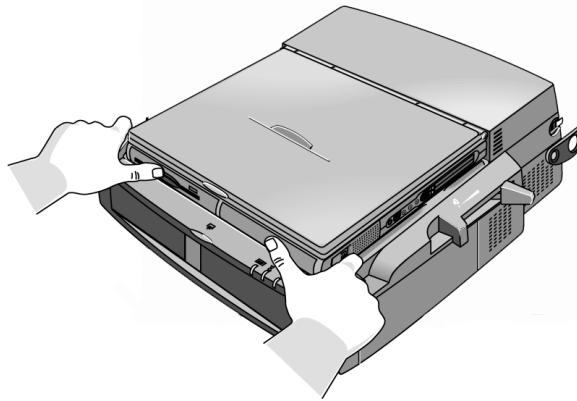

Figure 1-8. Docking the OmniBook

When the OmniBook is properly inserted, the amber wait light³ turns on. When the OmniBook is ready for use, the green docked light² turns on.

Note

If the OmniBook is in suspend or hibernate mode or if the OmniBook is turned off, the lights will not change until the OmniBook is turned on.

To Undock the OmniBook

Caution

If you have installed the tray security post, make sure that no objects (such as a phone jack or network connector) are protruding from the OmniBook PC card slots.

1. If there is no ac power connected to the dock, turn on the OmniBook to provide power for undocking.
 2. The dock will not operate in this power mode.
 3. Exit any applications that are using devices that are connected through the dock (network, USB, and PCMCIA devices.)
 4. Press the undock button **1** on the dock.
- or –
- If you are using Windows 95 or Windows 98, click Start, Eject PC.
- The amber wait light **3** then turns on.

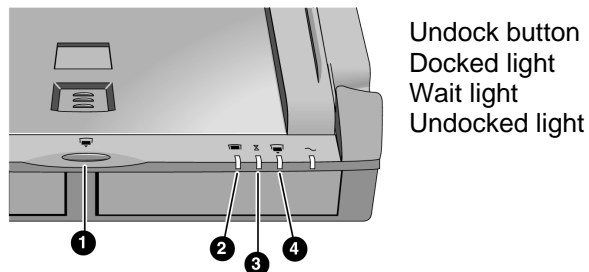

Figure 1-9. Dock Undock Button and LEDs

5. If you have enabled a docking password, you will be prompted for your password. You must enter it to undock the OmniBook.
 6. When you hear two beeps and the undock light **4** flashes, pull the release lever on the right side of the dock toward the front to eject the OmniBook.
- You have 30 seconds to pull the release lever. After 30 seconds, the dock relocks the OmniBook.

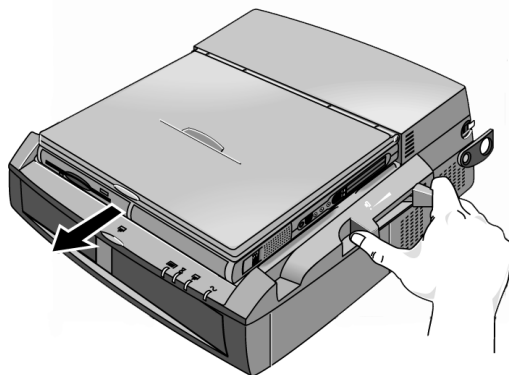

Figure 1-10. Ejecting the OmniBook from the Dock

To Manually Undock the OmniBook

If you cannot undock the OmniBook using the undock button (for example, you have no ac power or battery power), you can manually undock the OmniBook. Manual undocking overrides password protection.

Caution

Be sure to shut down the OmniBook before manually undocking it. Manually undocking the OmniBook while the unit is turned on. may cause the system to hang.

1. Save your work and turn off the OmniBook. Be sure to use the shut down option from the Start menu.
2. If you are using a Kensington MicroSaver lock to secure the dock, remove the lock.
3. Pull out and hold the manual release tab on the right rear corner of the dock while pulling the release lever toward the front to eject the OmniBook.

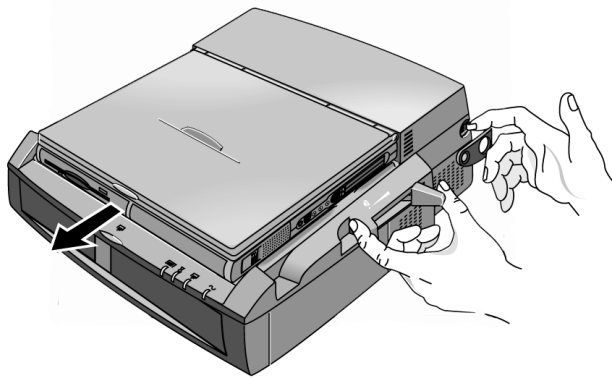

Figure 1-11. Manually Undocking the OmniBook

To Turn the OmniBook On and Off

To turn on the OmniBook:

- Press the power button **1** on the left side of the dock.

To turn off the OmniBook without undocking.

1. Save your work and close open applications .
2. Properly shut down the operating system.
3. Press the system-off **2** button on the left side of the dock.

To suspend the OmniBook without undocking.

1. Close open applications and save your work.
2. Press the power button **1** on the left side of the dock.

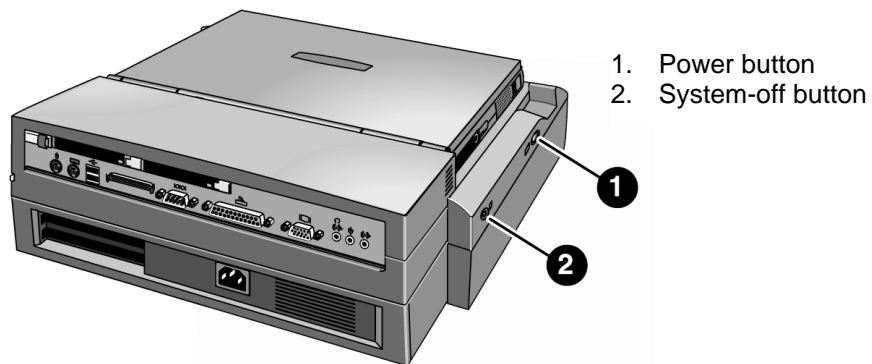

Figure 1-12. Turning the OmniBook On and Off

Specifications

The following table lists the specifications for the docking system.

Table 1-1. Docking System Specifications

Ports	240-pin docking connector. Parallel DB25 (EPP/ECP and floppy drive). Serial DB9 (115,200-bps). VGA port, D-sub 15-pin female connector – DDC compliant. 6-pin external keyboard connector. 6-pin external PS/2 mouse connector. Compact SCSI-2 connector. Three audio jacks for Speaker-out, Line-in, and Microphone-in. AC power connector. 2 PCI half-length slots. 2 Type II or Type III PC Card slots. 2 universal serial bus (USB) ports. PC expansion device bay. Plug-in module bay.
Power	Input: 100 to 240 Vac (50 to 60 Hz), 2.5A.
Security	Kensington lock slot secures dock , OmniBook, PC cards, PCI boards, and plug-in modules.
Size (without monitor stand) Height: Depth: Width:	130.0 mm (5.13 in.). 401.0 mm (12.60 in.). 428.0 mm (16.85 in.).
Weight	7.9. kg (17.4 lb).
Environmental Operating temperature: Storage temperature: Relative humidity:	5 to 35 °C (41 to 95 °F). –20 to 50 °C (–4 to 122 °F). 10% to 90% (noncondensing).
Major ICs	SCSI-2: Symbios 53C810AE CardBus: TI PCI1220 IDE: CMD PCI0646U2 PCI-PCI Bridge: Intel 380FB

Internal Design

The following figure shows the connections among the replaceable electronics module. See Table 1-2 for a list of the components and functions of the modules.

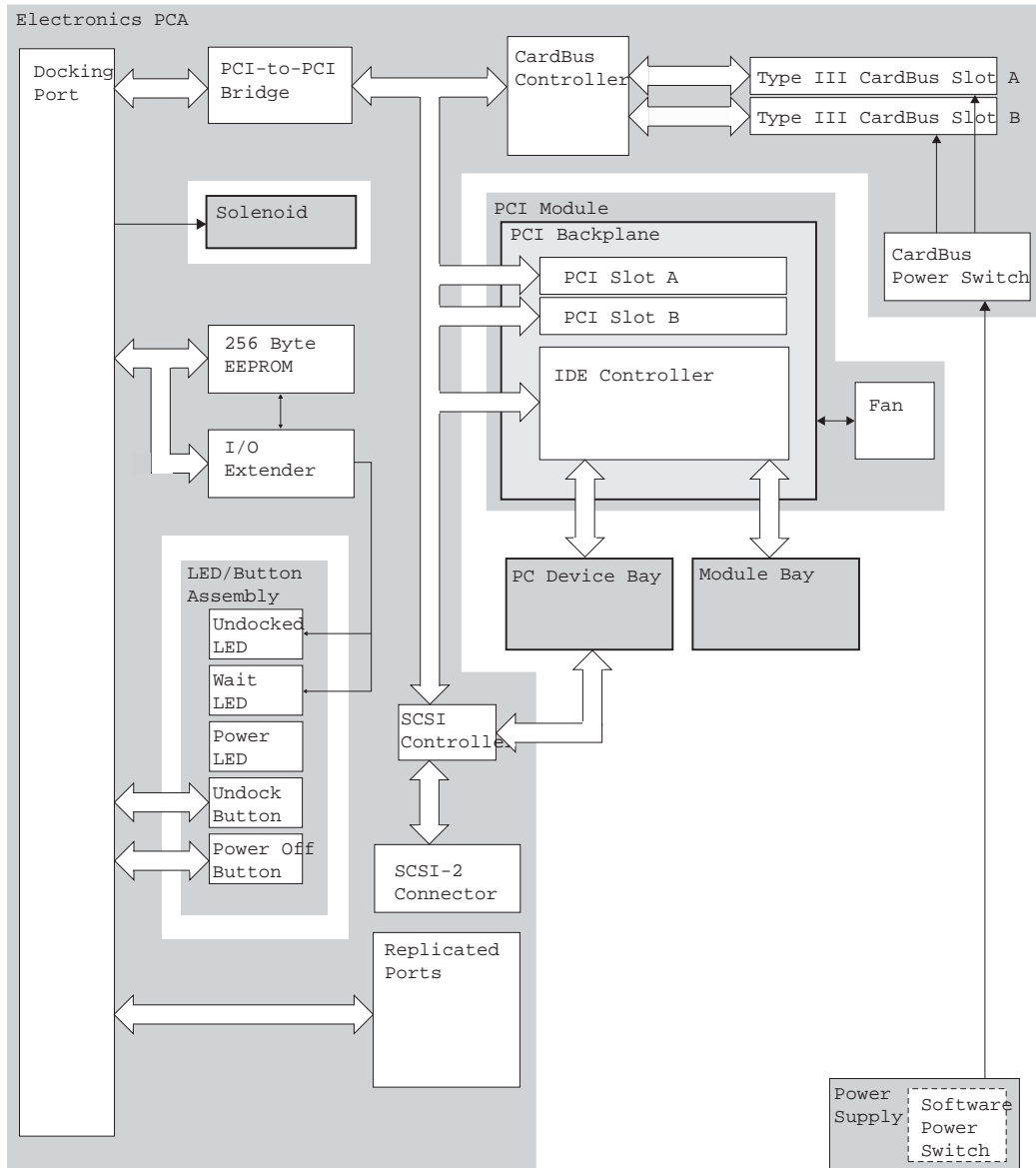

Figure 1-13 Replaceable Module Diagram

Table 1-2. Module Components/Functions

Module	Major Functions/Components
Electronics PCA	Docking port SCSI controller CardBus controller CardBus slots PCI to PCI bridge I/O Extender 256 Byte EEPROM Replicated ports Mouse port Keyboard port 2 Universal serial buses (USB) SCSI-2 port Serial port Parallel port Monitor port Headphones or speaker-out connector Microphone-in connector Audio line-in connector
PCI Backplane	IDE controller PCI slots
Power Supply	Power Conversion Vin: 90-250VAC Vout: 19V, 12V, 5V, 3.3 V DC Software power switch
PC Device Bay	SCSI and IDE PC devices
Module Bay	With module bay adapter, accepts OmniBook plug-in modules
LED-Button PCA Assembly	Dock buttons and LEDs

Removal and Replacement

This chapter tells you how to remove and replace the following components and assemblies. The ones marked by • in the following table are user-replaceable. The callouts in the illustrations in the removal and replacements match those in the exploded view on page 4-2 for easy identification.

Table 2-1. Removal Cross-Reference

• Tray (page 2-2).	Housing, module bay (page 2-17).
• Cover, top (page 2-2).	Power supply (page 2-18).
Shield, cable protection (page 2-4).	Solenoid (page 2-19).
• Cables, IDE and SCSI (page 2-6).	Assembly, LED/button (page 2-20).
• Cables, audio (page 2-7).	Lever, release (page 2-21).
Cable, PCI (page 2-8).	Cover, electronics module (page 2-22).
• Housing, PC module (page 2-9).	Module, electronics (pages 2-24, 2-23).
• Door, PCI (page 2-11).	PCA, electronics (page 2-25).
Housing, PCI (page 2-12).	PCMCIA socket (page 2-26).
Backplane, PCI (page 2-14).	Bezel, front (page 2-27).
Fan, PCI (page 2-15).	Bezel, rear (page 2-29).
• Adapter, module bay (page 2-16).	• Covers, module bay and PC module.

Caution

Always provide proper grounding when performing repairs. Without proper grounding, an electrostatic discharge may damage the dock and its components.

Note

Reassembly steps are the reverse of the removal steps. Reassembly notes are included at the end of each section below.

Table 2-2. Required Equipment

• Small Phillips screwdriver, magnetized.
• Medium Phillips screwdriver, magnetized
• Medium right-angle Phillips screwdriver
• 5 mm hex driver.
• Small flat-blade screwdrivers (or equivalent tools for prying).

Removing the Tray

(User-Replaceable)

Required Equipment

- None.

Removal Procedure

- Slide the tray release latch forward until the tray pops up, then lift the tray out of the dock.

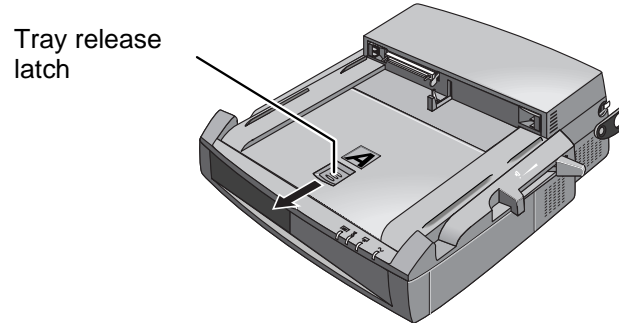

Figure 2-1. Removing the Tray

Opening the Top Cover (User-Replaceable)

Required Equipment

- Medium Phillips screwdriver, magnetized.

Removal Procedure

1. Undock the OmniBook.
2. Remove the tray, if installed.
3. Disconnect all cables connected to the rear of the dock.
4. Disconnect the power cord from the dock.
5. Remove the Kensington lock, if attached.
6. Remove the five screws securing the top cover to the base.

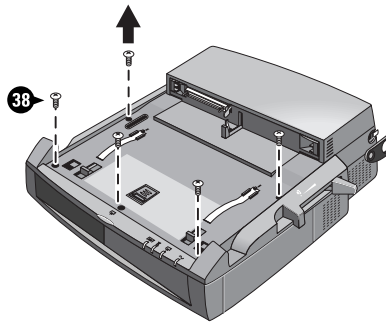

Figure 2-2. Removing the Top Cover Screws

7. Slide the top cover toward the back of the dock about 1 cm (1/2 inch).

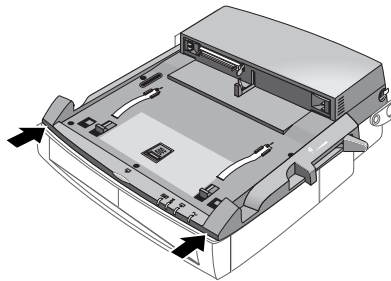

Figure 2-3. Sliding the Top Cover Back

CAUTION

Slide the top cover toward the back of the dock about 1 cm (1/2 inch) before lifting. Lifting the top cover without sliding it back will damage the dock.

8. Fold the top cover back until it lies flat on the work surface. Be careful not to pull any cable connectors loose.

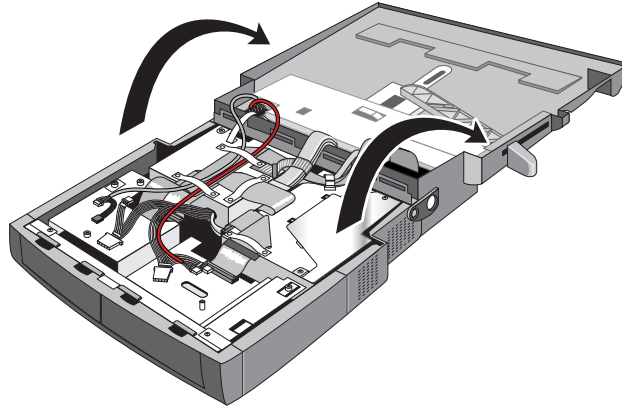

Figure 2-4. Folding the Top Cover Back.

Reassembly Note

Caution

When closing the top cover of the dock, make sure all cables are placed so that they will not be pinched and connectors will not be pulled loose.

Removing the Cable Protection Shield

(HP Authorized Service Providers Only)

Required Equipment

- Medium Phillips screwdriver.

Removal Procedure

1. Open the top cover of the Dock (see page 2-3).
2. Remove the two screws securing the cable protection shield to the dock.
3. Carefully slide the shield toward the back and to the left to release the tabs on the shield, then lift it out.

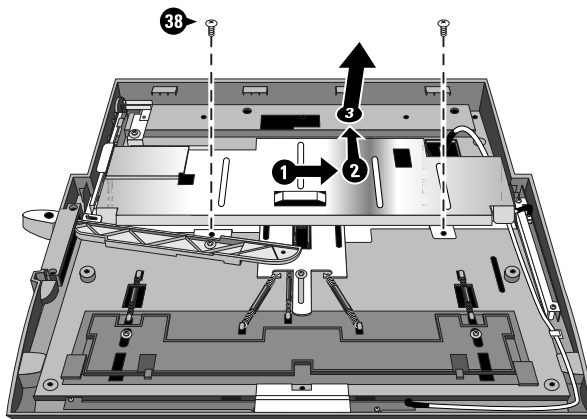

Figure 2-5. Removing the Cable Protection Shield

Removing the IDE and SCSI Cables (User-replaceable)

Required Equipment

- Medium Phillips screwdriver.
- Small flat-bladed screwdriver for prying.

Removal Procedure

1. Open the top cover of the Dock (see page 2-3).
2. Disconnect IDE cables 1 and 2 from any devices in the module bay adapter and PC device housing.
3. Disconnect the SCSI cable from any SCSI device in the PC device housing and disconnect the other end of the cable from the electronic module.
4. With a flat-bladed screwdriver, pry up one end of each of the three plastic cable clamps securing the cables to the top of the power supply and PCI housing.
5. Slide the cables out from under the clamps and remove from the dock.

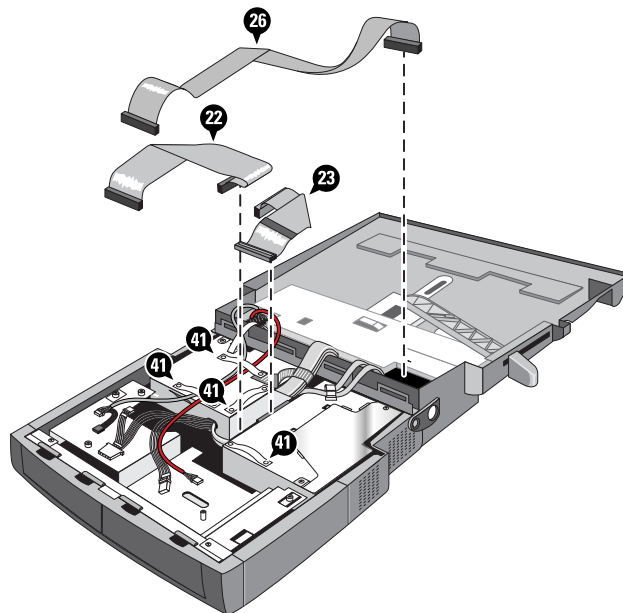

Figure 2-6. Removing the IDE and SCSI Cables

Removing the Audio Cables

(User-replaceable)

Required Equipment

- Medium Phillips screwdriver.
- Small flat-bladed screwdriver for prying.

Removal Procedure

1. Open the top cover of the Dock (see page 2-3).
2. Disconnect audio cables 1 and 2 from any devices in the module bay adapter and PC device housing and from the electronics module.
3. With a flat-bladed screwdriver, pry up one end of the plastic cable clamp securing the cables to the top of the power supply.
4. Slide the cables out from under the clamps and remove from the dock.

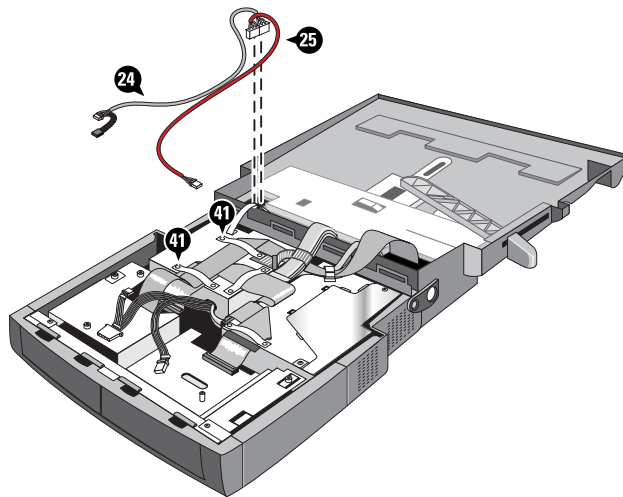

Figure 2-7. Removing the Audio Cables

Removing the PCI Cable

(HP Authorized Service Providers Only)

- See “Removing the PCI Housing” on page 2-11.

Removing the PC Module Housing (User-Replaceable)

Required Equipment

- Medium Phillips screwdriver.
- Small flat-bladed screwdriver for prying.

Removal Procedure

1. Open the top cover of the Dock (see page 2-3).
2. Remove the cover plate from the PC module bay (see page 2-27).
3. Remove the two screws securing the PC module housing and remove the housing from the dock.

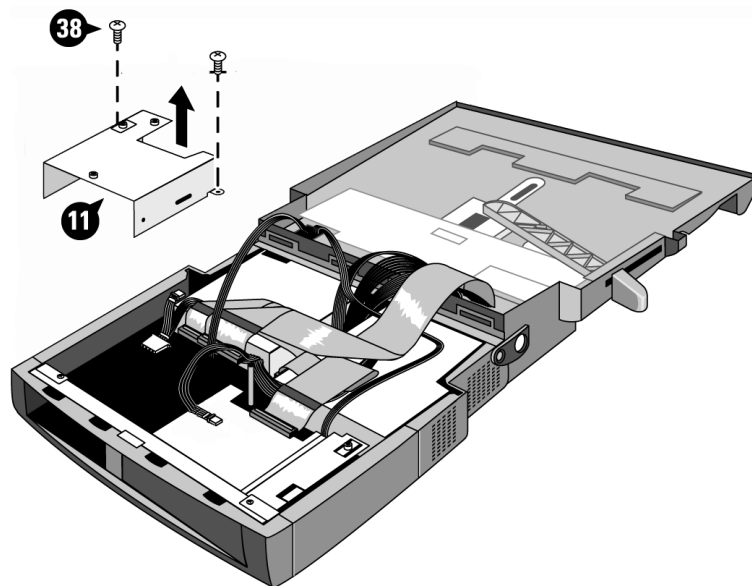

Figure 2-8. Removing the PC Module Housing

4. Disconnect power cable 1, IDE cable 1 or the SCSI cable, and audio cable 1 from any device installed in the PC module housing.
5. Remove the 3 ½ inch adapter kit or 5 ¼ inch device from the housing.

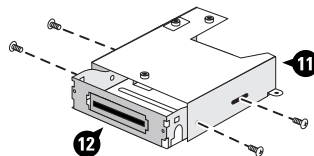

Figure 2-9. Removing the 3 ½ Inch Adapter Kit or 5 ¼ Inch Device

6. Remove the 3 ½ inch device from the adapter kit. The four mounting screws may be on either the sides or bottom, depending on the device you are installing.

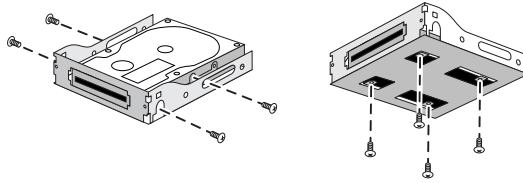

Figure 2-10. Removing a 3 ½ Inch Device

Reassembly Note

1. Reconnect power cable 1 to the device, then connect either IDE cable 1 or the SCSI cable and audio cable 1 to the PC before re-installing the PC device housing in the dock.. Both the power cable and audio and power cables have two connectors. Select the connectors that matches the PC device.
2. Insert the module slightly through the opening in the front of the dock (from inside the dock) and lay it flat in the dock, then slide the unit back until the tabs on the housing are secured by the retainer on the bottom of the dock and the screw holes are properly aligned.

Removing the PCI Door

(User Replaceable)

Required Equipment

- None

Removal Procedure

- Remove the PCI door by pulling the lock tab on the door out from the dock.

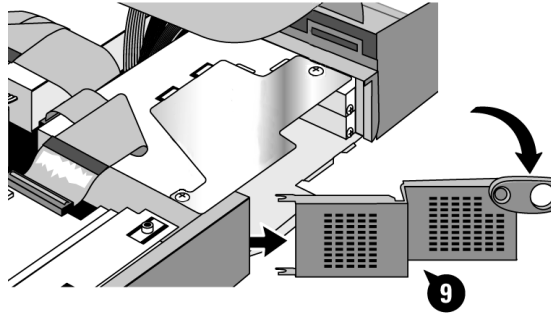

Figure 2-11. Removing the PCI Door

Removing the PCI Housing

(HP Authorized Service Providers Only)

Required Equipment

- Medium Phillips screwdriver.
- Flat-bladed screwdriver for prying.

Removal Procedure

1. Open the top cover of the Dock (see page 2-3).
2. Remove the PCI door (see page 2-11).
3. Remove the IDE 2 cable (page 2-4) and disconnect IDE cable 1 from the connector on the PCI backplane.
4. Disconnect the power cable from the connector on the PCI backplane.
5. Unclip the power cable and SCSI cable from top of the PCI housing and move it out of the way.
6. Remove the plastic pin securing the PCI cable strap to the top of the power supply.
7. Remove the screw securing the metalized plastic strap to the top of the PCI housing.
8. Remove the screw securing the PCI cable bracket and grounding strap to the PCI housing.
9. Remove the cable protection shield (see page 2-5).
10. Remove the screws securing the PCI cable bracket and grounding strap top cover of the dock.
11. Disconnect the PCI cable from the electronics module.
12. Remove the three screws securing the PCI housing to the base of the dock.
13. Lift the PCI housing until the PCI cable connectors are easily accessible and carefully disconnect the three PCI cables from the PCI backplane.
14. Remove the PCI housing from the dock.

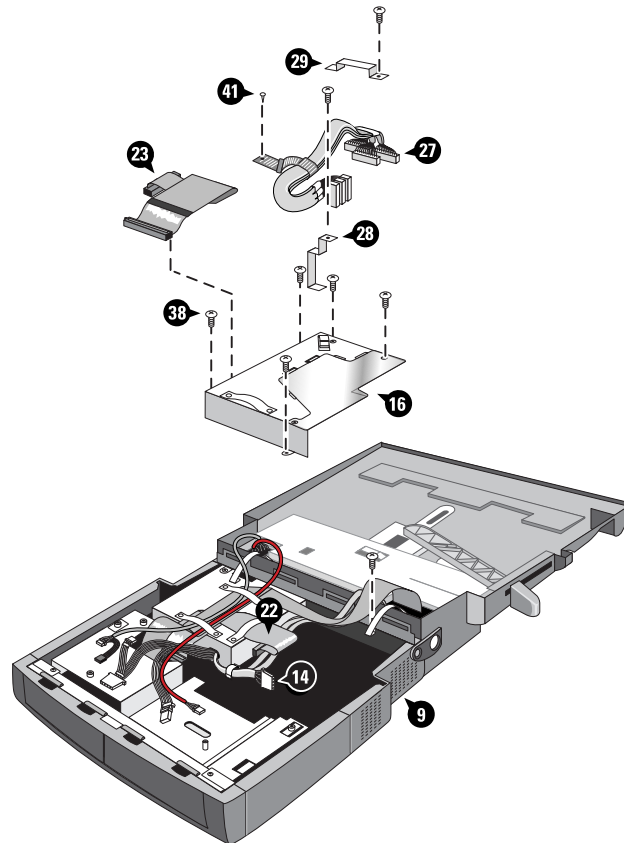

Figure 2-12. Removing the PCI Housing

Reassembly Note

Reconnect the PCI cable and power supply cable to the PCI backplane before re-installing the PCI housing in the dock.

The PCI cable connectors are color-coded. When reconnecting the cables, make sure the color on each cable connector matches the label by the connector on the dock.

Removing the PCI Backplane

(HP Authorized Service Providers Only)

Required Equipment

- Medium Phillips screwdriver.

Removal Procedure

1. Open the top cover of the Dock (see page 2-3).
2. Remove the PCI door (see page 2-11).
3. Remove the PCI housing from the dock (see page 2-11).
4. Remove the remaining screw securing the hinged section of the PCI housing and fold the section back for easy access to the backplane.
5. Disconnect the fan cable from the PCI backplane. You may need to carefully lift the front edge of the connector to avoid the black component on the backplane immediately in front of the connector in order to disconnect the cable.
6. Remove the two screws securing the PCI backplane to the PCI housing.
7. Carefully lift the bottom of the backplane and pull it out.

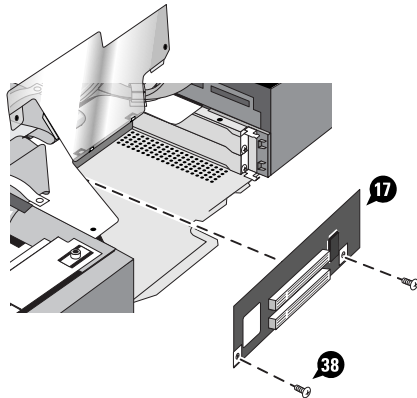

Figure 2-13. Removing the PCI Backplane

Removing the PCI Fan

(HP Authorized Service Providers Only)

Required Equipment

- Medium Phillips screwdriver.

Removal Procedure

1. Open the top cover of the Dock (see page 2-3).
2. Remove the PCI door (see page 2-11).
3. Remove the PCI housing from the dock (page 2-11).
4. Disconnect the PCI cable from the PCI backplane connector (page 2-8).
5. Remove the PCI backplane from the PCI housing (page 2-14).
6. Remove the two screws securing the PCI fan to the PCI housing.
7. Remove the fan and the screen behind it. Set the screen aside for reuse.

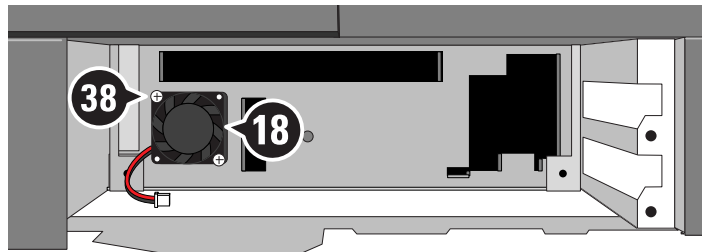

Figure 2-14. Removing the PCI Fan

Reassembly Note

Be sure to reinstall the screen removed in step 6 before reinstalling the fan.

Removing the Module Bay Adapter (User-Replaceable)

Required Equipment

- Medium Phillips screwdriver.

Removal Procedure

1. Open the top cover of the Dock (see page 2-3).
2. Disconnect IDE cable 2, audio cable 2, and power cable 2 from the connectors protruding from the back of the module bay adapter. See pages 2-6 and 2-7.
3. Remove the locking screw in the hole in the top of the module bay housing to release the module adapter in the bay.
4. Press down on the module bay adapter latch (inside the module bay on the bottom on the dock.) and pull the module bay adapter from the module bay housing.
5. Re-insert the locking screw in the module bay housing.

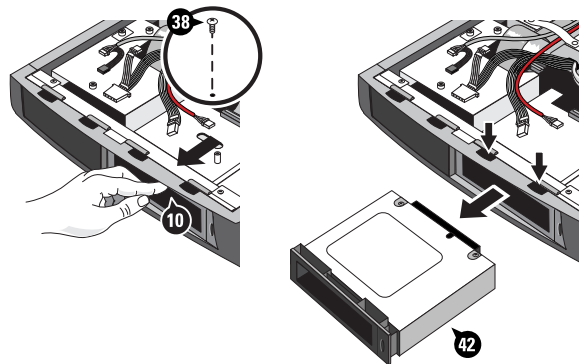

Figure 2-15. Removing the Module Bay Adapter from the Dock

Removing the Module Bay Adapter Housing

(HP Authorized Service Providers Only)

Required Equipment

- Medium Phillips screwdriver.

Removal Procedure

1. Open the top cover of the Dock (see page 2-3).
2. Remove the PCI housing (see page 2-11).
3. Remove the two screws securing the module bay housing to the base of the dock.
4. Slide the housing toward the back of the dock and lift it out.

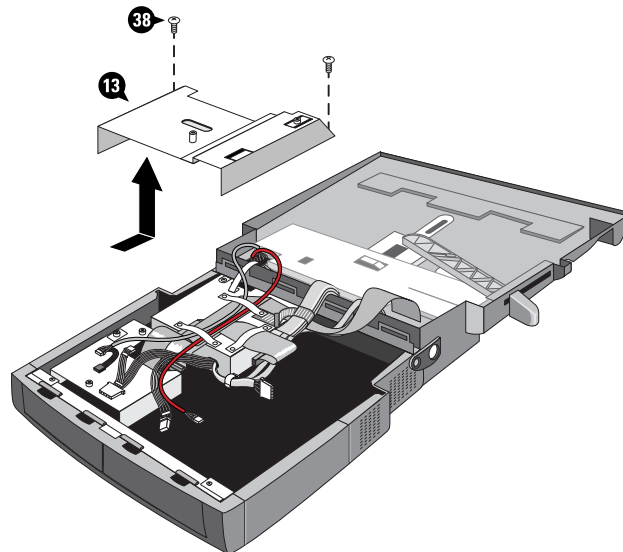

Figure 2-16. Removing the Module Bay Adapter Housing

Removing the Power Supply

(HP Authorized Service Providers Only)

Required Equipment

- Medium Phillips screwdriver.
- Flat-bladed screwdriver for prying.

Note

There are no replaceable parts in the power supply. If the fan or any other component of the power supply fails, replace the entire power supply.

Removal Procedure

1. Open the top cover of the Dock (see page 2-3).
2. Remove the SCSI cable and IDE1 cables from the top of the power supply. See page 2-6.
3. Remove the audio cables from the top of the power supply. See page 2-7.
4. Remove the cable protection shield (see page 2-5).
5. Disconnect the power connectors from the module bay adapter, PC device (if connected), and the electronics PCA.
6. Remove the four screws securing the power supply to the base of the dock.
7. Lift the power supply out of the dock.

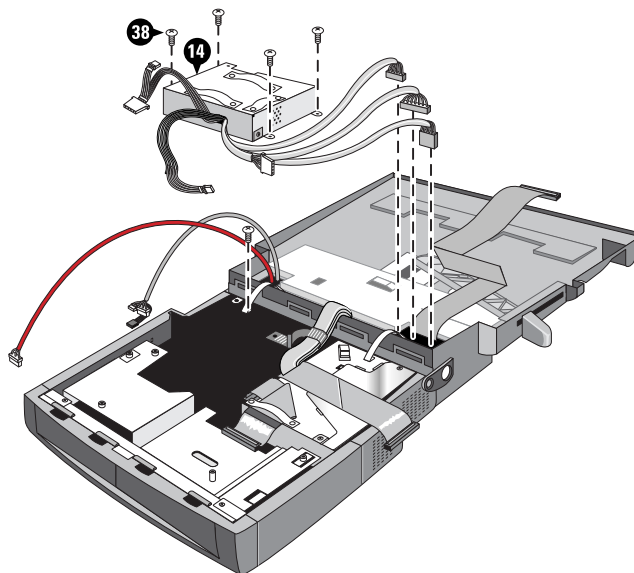

Figure 2-17. Removing the Power Supply

Removing the Solenoid

(HP Authorized Service Providers Only)

Required Equipment

- Medium right-angle Phillips screwdriver.

Removal Procedure

1. Open the top cover of the Dock (see page 2-3).
2. Remove the cable protection shield (page 2-4).
3. Remove the two screws holding the solenoid in place.
4. Unplug the solenoid cable from the electronic module.

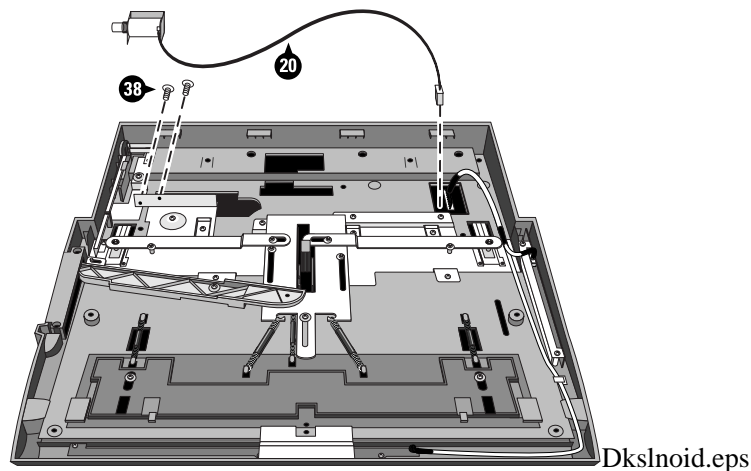

Figure 2-18. Removing the Solenoid

Reassembly Note

When reinstalling the solenoid, make sure that the solenoid is correctly aligned with the slot in the security bar in the dock. The solenoid tip must be parallel or tilted slightly down so that the tip fits in the center of the slot.

Using an OmniBook, dock and undock several times to verify that the OmniBook released smoothly and there is no resistance to movement of the solenoid tip in and out of the security bar slot. If there is resistance, adjust the solenoid and retest the release mechanism.

Removing the LED/Button Assembly

(HP Authorized Service Providers Only)

Required Equipment

- Medium Phillips screwdriver.
- Flat-bladed screwdriver for prying.

Removal Procedure

1. Open the top cover of the Dock (see page 2-3).
2. Remove the cable protection shield. (See page 2-4).
3. Disconnect the LED/button assembly connector from the electronics PCA.
4. Peel back or remove the tape over the undock button. Save the tape for reuse.
5. Remove the 5 screws securing the assembly and lift it out of the dock.

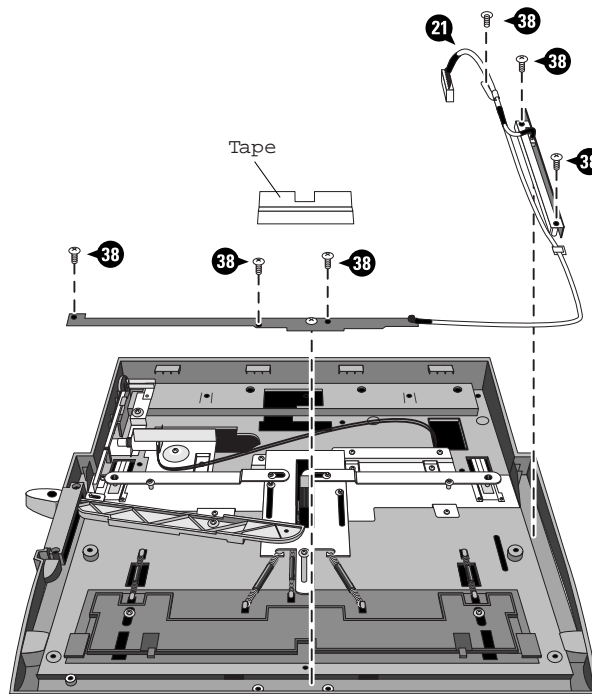

Figure 2-19. Removing the LED/Button Assembly

Caution

Do not remove the screw securing the Undock button to the LED/button assembly.

Reassembly Note

When reinstalling the LED/Button assembly, be sure to reapply the tape you removece in step 3.

Removing the Release Lever

(HP Authorized Service Providers Only)

Required Equipment

- Medium Phillips screwdriver.

Removal Procedure

1. Open the top cover of the Dock (see page 2-3).
2. Remove the two screws securing the plastic release lever retaining plate.
3. Remove the screw retaining the release lever and lift the lever out.

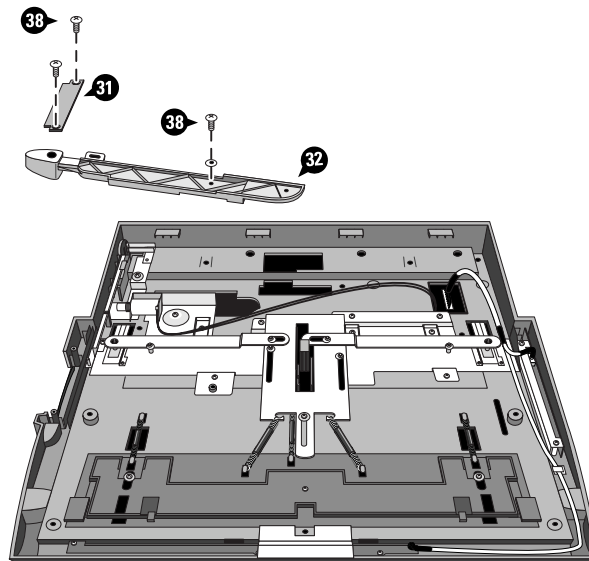

Figure 2-20. Removing the Release Lever

Reassembly Note

Make sure the pin on the mechanical assembly is properly positioned in the arm's slot and that the pin on the arm is properly positioned in the sliding mechanism

Removing the Electronics Module Cover (HP Authorized Service Providers Only)

Required Equipment

- Medium Phillips screwdriver.

Removal Procedure

1. Open the top cover of the Dock (see page 2-3).
2. Disconnect all cables from the top of the dock that connect to the dock's base.
3. Remove the two metalized plastic straps holding the top and base of the dock together.
4. Pull the manual release lever forward and insert a screwdriver to hold it in the open position)
5. Remove the screw in the corner under locking bar.
6. Remove the remaining four screws securing the electronics module cover.
7. Turn the top of the dock over.
8. Press center of the cover towards the rear of the dock to release it, then lift it off.

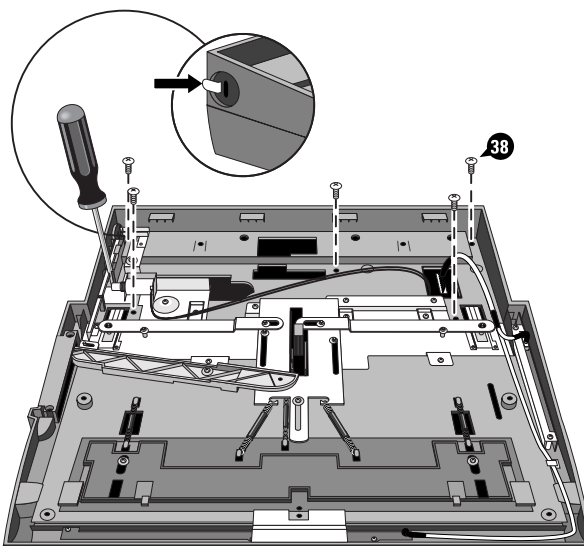

Figure 2-21. Removing the Electronics Module Cover

Removing the Electronics Module

(HP Authorized Service Providers Only)

Required Equipment

- Medium Phillips screwdriver.

Removal Procedure

1. Open the top cover of the Dock (see page 2-3).
2. Remove the cable protection Shield (see page 2-5).
3. Remove all cables connected to the electronics module.
4. Remove the electronics module cover (see page 2-22).
5. Remove the six screws securing the module to the dock top
6. Make sure the PC card slot locking mechanism is in the unlocked position.
7. Carefully remove the module from the dock top.

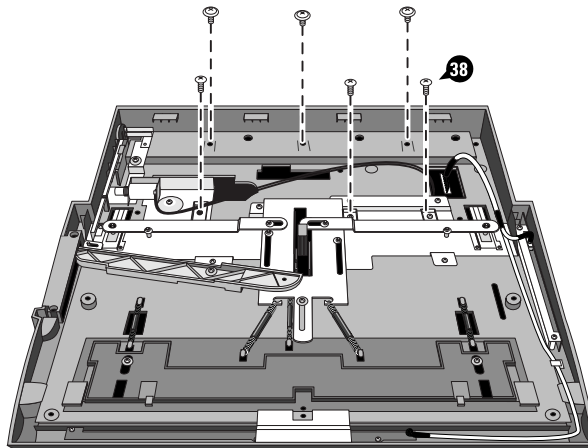

Figure 2-22. Removing the Electronics Module.

Opening the Electronics Module

(HP Authorized Service Providers Only)

Required Equipment

- Medium Phillips screwdriver.

Removal Procedure

1. Open the top cover of the Dock (see page 2-3).
2. Remove the cable protection Shield (see page 2-5).
3. Removing the Electronics Module Cover (see page 2-22).
4. Remove the Electronics Module PCA (see page 2-23).
5. Remove the 14 screws securing the bottom of the Electronics module.
6. Lift the bottom off.

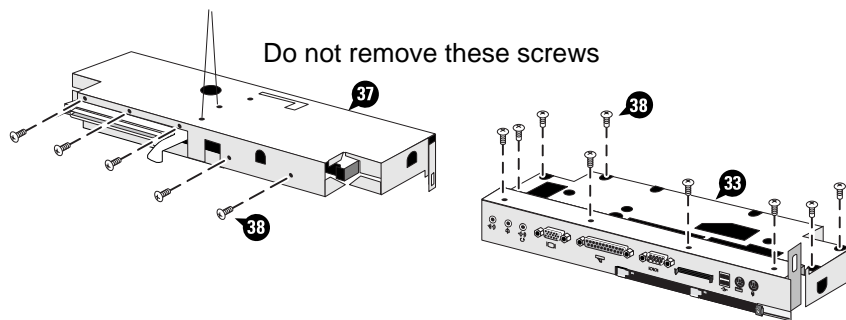

Figure 2-23. Opening the Electronics Module

Caution

Do not remove the two screws on the top of the module retaining the docking latch.

Removing the Electronics PCA

(HP Authorized Service Providers Only)

Required Equipment

- Medium Phillips screwdriver.
- 5-mm hex driver.

Removal Procedure

1. Open the top cover of the Dock (see page 2-3).
2. Remove the cable protection Shield (see page 2-5).
3. Remove the Electronics Module Cover (see page 2-22).
4. Remove the Electronics Module (see page 2-23).
5. Open the electronics module (see page 2-24).
6. Remove the nuts securing the serial port, parallel port, and monitor port connectors.
7. Remove the two screws securing the SCSI connector.
8. Remove the screw securing the electronics PCA to the top of the electronics module.
9. Carefully lift the front of the board and remove it from the top of the electronics module.

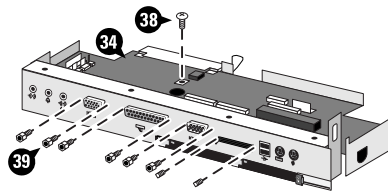

Figure 2-24. Removing the Electronics PCA

Removing a PCMCIA Socket

(HP Authorized Service Providers Only)

Required Equipment

- Small Phillips screwdriver, preferably magnetized.

Removal Procedure

1. Open the top cover of the Dock (see page 2-3).
2. Remove the cable protection Shield (see page 2-5).
3. Remove the Electronics Module Cover (see page 2-22).
4. Remove the Electronics Module (see page 2-23).
5. Open the electronics module (see page 2-24).
6. Remove the electronics module PCA (see page 2-25).
7. Remove the four black screws securing the socket to the electronics PCA.
8. Carefully lift the socket at the connector end to disconnect the connector and remove the socket.

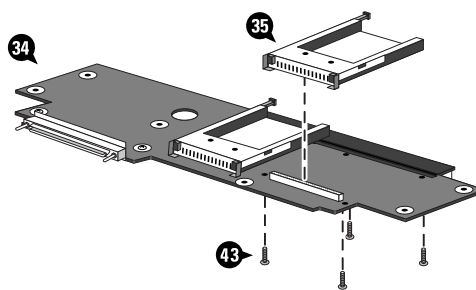

Figure 2-25. Removing a PCMCIA Socket

Removing the Module Bay and PC Device Slot Covers

(User Replaceable)

Required Equipment

- None.

Removal Procedure

1. Open the top cover of the dock (see page 2-3)
2. Press down on the tabs on the top of the covers and push them forward out of the dock.

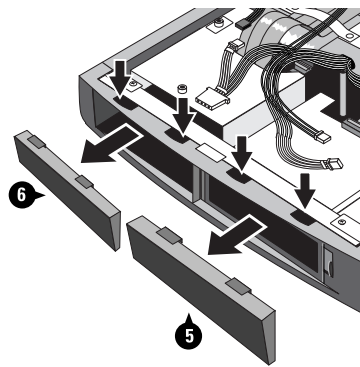

Figure 2-26. Removing the Module Bay and PC Device Slot Covers

Removing the Front Bezel

(HP Authorized Service Providers Only)

Required Equipment

- Medium Phillips screwdriver.

Removal Procedure

1. Open the top cover of the dock (see page 2-3)
2. Remove the module bay adapter, if installed.
3. Remove the screw securing the front bezel to the base of the dock.
4. Pull out the left side of the bezel, then pull out the right of the bezel from the base of the dock.

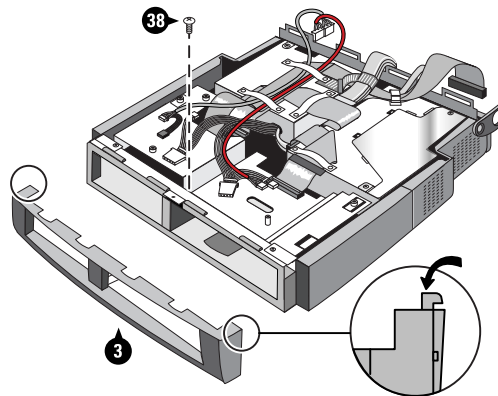

Figure 2-27. Removing the Front Bezel

Reassembly Note

Install the right side of the bezel first, then press the left side in place.

Removing the Rear Bezel

(HP Authorized Service Providers Only)

Required Equipment

- Medium Phillips screwdriver.

Removal Procedure

1. Open the top cover of the dock (see page 2-3)
2. Remove the cable protection Shield (see page 2-5).
3. Disconnect all cables connecting the top of the dock to the base.
4. Disconnect the top cover of the dock by removing the metalized plastic straps holding the top and base together and move the top cover out of the way.
5. Remove the screw securing the rear bezel to the base of the dock.
6. Pull out the left side of the bezel, then pull out the right of the bezel from the base of the dock.

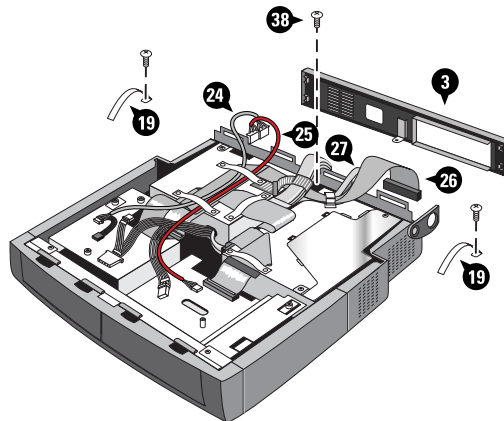

Figure 2-28. Removing the Rear Bezel

Reassembly Note

Reinstall the right side of the bezel first.

Troubleshooting and Diagnostics

This chapter includes troubleshooting and diagnostic information for testing the functionality of the Docking System and identifying faulty modules:

- Troubleshooting information
 - Troubleshooting the problem (page 3-3).
 - Verifying the repair (page 3-3).
 - Suggestions for troubleshooting (page 3-4).
- Diagnostic tools
 - OmniBook hardware diagnostic program (page 3-8).
 - BIOS Setup utility (page 3-9).

Troubleshooting

The suggestions in this section can help isolate and repair the cause of a problem. To ensure quality repair, HP recommends that you follow the basic troubleshooting steps shown in the illustration below.

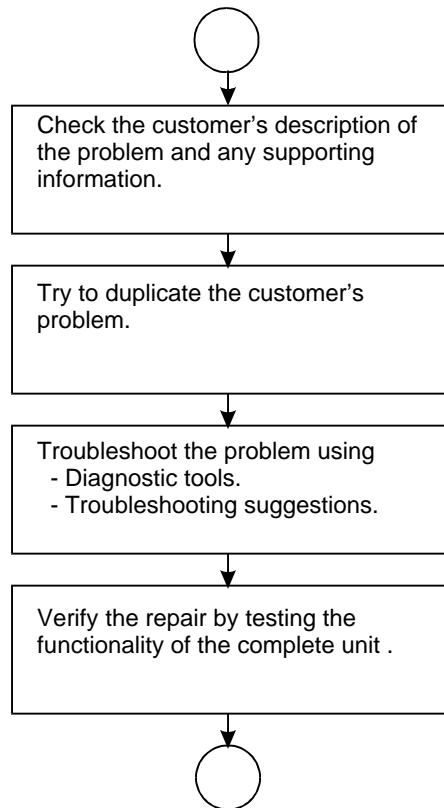

Figure 3-1. Basic Troubleshooting Steps

Troubleshooting the Problem

Record pertinent information about the unit:

- Serial number of dock.
- Model of OmniBook used with dock
- Operating system and version.
- BIOS version.
- Accessories and peripherals used.

Analyze the problem:

- **Observe Symptoms.** Using the customer's information, try to duplicate the problem. Determine how the problem differs from proper behavior. Also, take note of the functions that do work properly.
- **Separate Problems.** If there is more than one symptom, separate them into distinct problems.
- **Consider Causes.** Keep in mind possible causes for each problem. Use the diagnostic tools and troubleshooting suggestions to help find possible causes.
 - The OmniBook diagnostic program is the primary troubleshooting tool—it tests most components using automatic and interactive tests.
 - The troubleshooting suggestions on page 3-4 include general suggestions for repairing units with certain failure symptoms.

Some problems can be caused by failures in either the docking system or the OmniBook. Testing the dock with a known-good OmniBook is an ideal way to isolate the cause to the docking system.

It is rare for more than one module to be responsible for one failure symptom. Therefore, replacement of more than one module for a particular symptom should be the exception rather than the normal expectation.

Verifying the Repair

Before returning the repaired unit to the customer, verify the repair by running the following tests:

- **Basic Diagnostic Test.** Run the basic test of the OmniBook diagnostic program (page 3-8).
and–
- **Function Tests.** Run tests that check the repaired function, such as in the OmniBook diagnostic program (page 3-8).
and–
- **Failed Tests.** Run any other tests that failed during troubleshooting.

Suggestions for Troubleshooting

If you can't isolate the cause of a problem using the diagnostic tools, you can use the suggestions in the following table to help find the problem.

Table 3-1. Troubleshooting Suggestions

Symptom	Call Center: Suggestions	Repair Center: Likely Causes	Repair Center: Comments
To help determine likely causes, check to see what replaceable modules are involved in the system function and what roles they play. See the table on page 1-11.			
The amber Wait light remains on after the OmniBook is docked and the OmniBook does not recognize devices connected to the dock.	See the upgrade instructions or the readme file on the Upgrade CD-ROM provided with the docking system for information on how to determine which BIOS version the OmniBook has, and how to upgrade the BIOS if necessary.	An older BIOS may be installed in the OmniBook. BIOS versions earlier than version 2.00 do not support use of the docking system.	
The OmniBook does not undock after the undock button is pressed.	If no ac power is connected to the dock, make sure the OmniBook is turned on. If you are using a password, make sure it is accepted. If you are prompted about shutting down devices, and if no applications are using those devices, press ENTER. Otherwise, close those applications and try undocking again. Reboot the system and try again. Manually undock the OmniBook following the instructions in "To Manually Undock the OmniBook" on page 1-7. <i>Always reset the OmniBook after manually undocking.</i>	LED-Button PCA Assy. Electronics PCA.	

Symptom	Call Center: Suggestions	Repair Center: Likely Causes	Repair Center: Comments
If a rear-panel port connection does not work.	<p>Try connecting the device to the corresponding port on the OmniBook. This can tell you if the problem is with the dock.</p> <p>Make sure the OmniBook is fully inserted in the dock. The connection should be snug.</p> <p>Make sure the ends of the device cable are connected properly and terminated, if necessary.</p> <p>Make sure the device and the dock are connected and both have power connected and are turned on.</p> <p>Reboot the OmniBook.</p>	Electronics PCA.	
OmniBook battery discharges while docked.	<p>Make sure that the ac power cord is plugged into the dock and plugged into an ac outlet.</p> <p>Check the LEDs or icons on the OmniBook to see if ac power is detected by the OmniBook.</p>	Power Supply.	
An external PS/2 mouse or keyboard does not work.	<p>Try connecting the mouse or keyboard to the corresponding port on the OmniBook. This can tell you if the problem is with the dock.</p> <p>Make sure the mouse or keyboard is plugged into the correct port. The mouse and keyboard ports look the same.</p> <p>Check that the PS/2 mouse is enabled in the BIOS Setup utility.</p>	Electronics PCA.	
You cannot hear audio devices connected to the dock.	<p>Make sure sound is not muted by the OmniBook mute control.</p> <p>Try increasing the volume using the OmniBook volume control and the Windows volume control.</p> <p>Try connecting audio devices to the corresponding port on the OmniBook. This can tell you if the problem is with the dock.</p>	Electronics PCA.	

Symptom	Call Center: Suggestions	Repair Center: Likely Causes	Repair Center: Comments
If an external serial mouse does not work.	Try connecting the mouse to the corresponding port on the OmniBook. This can tell you if the problem is with the dock. Check that the correct serial port is enabled in the BIOS Setup utility.	Electronics PCA.	
A PCI accessory board does not work.	Make sure the PCI accessory board is properly seated. Make sure that you have correctly followed any installation instructions provided with the board.	PCI accessory board. PCI cable. PCI backplane. Electronics PCA.	
A PCI accessory board is not recognized by the OmniBook.	Make sure the drivers for the PCI accessory board are installed. See the instructions provided with your PCI board.		
SCSI device in the PC device bay is not working properly.	Check that the SCSI, power 1, and audio 1 (if required) cables are securely connected to the device. Make sure the device has proper SCSI termination. If SCSI devices are connected to the SCSI port on the rear of the dock, make sure all devices are turned on and only the last device on the bus is terminated. Make sure all SCSI devices have a unique SCSI address from 0 to 6. Refer to the installation guide provided with the device for information on selecting a SCSI address.	Internal SCSI cable. SCSI device in bay. Electronics PCA.	

Symptom	Call Center: Suggestions	Repair Center: Likely Causes	Repair Center: Comments
SCSI devices connected to the SCSI port are not working properly.	<p>Make sure all devices are turned on and the last device on the bus is terminated.</p> <p>Check that SCSI interface cables are securely attached.</p> <p>If devices are daisy-chained, make that no devices in the middle of the chain are terminated.</p> <p>Make sure that all SCSI devices are turned on before starting your OmniBook.</p> <p>Make sure all SCSI devices have a unique SCSI address from 0 to 6. Refer to the installation guide provided with the device for information on selecting a SCSI address.</p>	<p>External SCSI cable.</p> <p>SCSI device.</p> <p>Electronics PCA.</p>	
The IDE device in the PC device bay is not working.	<p>Check that the IDE cable 1, power, and audio) cable 1 (if required are securely connected.</p> <p>Make sure the IDE device is set to "Master". If it still does not work, try the "Cable Select" or "CSEL" setting.</p> <p>Refer to the installation guide provided with the device for information on setting Master/Slave/Cable Select options.</p>	<p>IDE device.</p> <p>IDE cable.</p> <p>PCI backplane.</p> <p>Electronics PCA.</p>	
The module in the Module bay adapter is not working.	<p>Check that the IDE cable 2, power cable 2, and audio cable 2 (if required are securely connected.</p> <p>Connect IDE cable 1 and power cable 1 to the module bay and test its operation.</p> <p>Plug the module into your OmniBook and verify that it works in the OmniBook.</p> <p>The module bay adapter does not support floppy disk drives.</p>	<p>IDE device.</p> <p>IDE cable.</p> <p>Module bay adapter.</p> <p>PCI backplane.</p> <p>Electronics PCA.</p>	
I/O problems.	<p>Check that ac power is connected.</p> <p>Check settings in BIOS Setup.</p> <p>Try using the corresponding OmniBook port.</p>	<p>Electronics PCA.</p>	

Diagnostic Tools

This section describes the following diagnostic tools you can use for troubleshooting and repairing the OmniBook:

- OmniBook hardware diagnostic program (below).
- BIOS Setup utility (page 3-9).

OmniBook Diagnostic Program

The OmniBook hardware diagnostic program provides two levels of testing:

- User-level testing using the basic hardware test.
- Advanced testing using the individual hardware tests.

Running the Diagnostic Test

The tests are designed to run after the system reboots. This ensures that the computer will be in a predictable state, so the diagnostic program can properly test the hardware components. The tests are non-destructive and are intended to preserve the state of the computer. The OmniBook reboots when you exit the program so drivers can be loaded.

See the service manual or reference guide for the OmniBook you are using for detailed about running the diagnostic test.

Interpreting the Results

- The following table lists test groups, error codes, and suggestions for follow-up actions. Consider these suggestions in combination with other troubleshooting information.

Table 3-2. Docking System Diagnostic Error Codes

Code	Error Description	Suggestions
9071	Communication failure - bad test component	Update BIOS in OmniBook Replace electronics PCA.
9073	Timeout - bad test component	Update BIOS in OmniBook Replace electronics PCA.
9075	Bad read/read - bad EEPROM	Replace electronics PCA.
9077	Bad EEPROM initialization - bad EEPROM	Replace electronics PCA.
9078	Bad EEPROM checksum - bad EEPROM	Replace electronics PCA.
907B	Bad LED	Replace LED/button assembly.
9082	Bad PCI, bad pullup resistor in notebook.	Retry test with known good OmniBook. Replace electronics PCA.
9088	Bad device header - not proper dock, improper dock hardware	Replace electronics PCA.

BIOS Setup Utility

The BIOS Setup utility provides access to basic configuration settings. Some BIOS settings affect dock functionality. Refer to the BIOS Setup utility information in the service documentation for the OmniBook being used with the docking system for more information.

Replaceable Parts

This chapter contains an exploded view of the OmniBook and the following lists of parts:

- Docking system replaceable parts (page 4-3).
- Docking system power cords (page 4-4).
- Docking system Accessories (page 4-4).

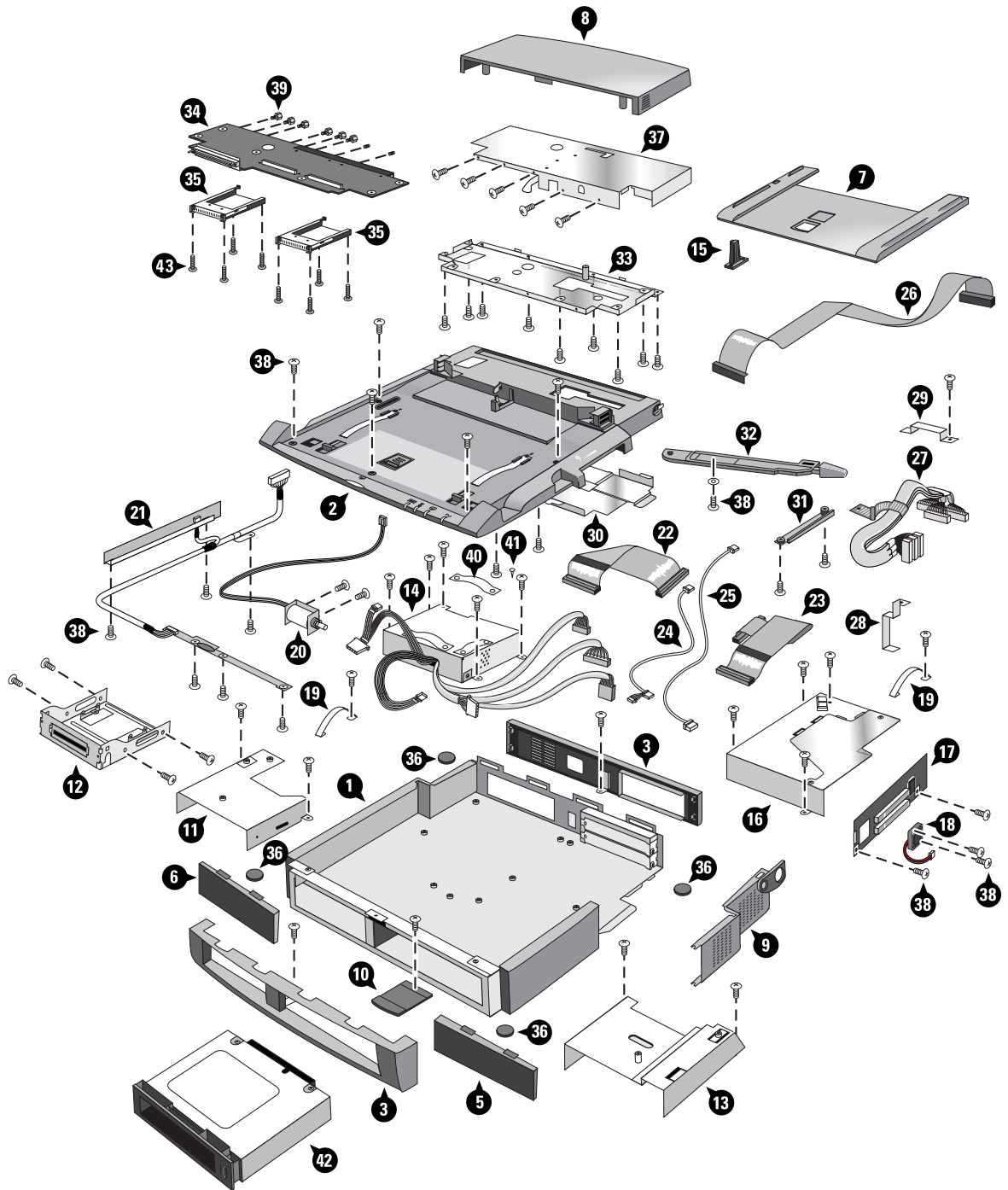

Figure 4-1. Exploded View

Table 4-1. Docking System Replaceable Parts

	Description	Part Number	Exchange Part Number	User Repl.
	Monitor stand, tall (Not shown in exploded view)	F1477-60936		Yes
1	Base	F1477-60910		
2	Assy, Dock Mechanical metalized (top cover)	F1477-60925		
3	Bezel, Front	F1477-60911		
4	Bezel, Rear	F1477-60912		
5	Cover, Module Bay	F1477-60920		Yes
6	Cover, PC Bay	F1477-60919		Yes
7	Tray, A (OB71xx) Metalized	F1477-60955		Yes
7	Tray, B (OB41xx) Metalized	F1477-60956		Yes
7	Tray, C (OB21/31xx) Metalized	F1477-60957		Yes
8	Cover, Electronics Module	F1477-60921		
9	Door, PCI	F1477-60917		
10	Latch, module	F1477-60960		
11	Housing, PC Device	F1477-60914		Yes
12	Adapter, 3.5-5.25"	5002-3655		Yes
13	Housing, Module Bay	F1477-60913		Yes
14	Power Supply	F1477-60909		
15	Security Post	F1452-60908		Yes
16	Housing, PCI	F1477-60915		
17	PCA, PCI Backplane	F1477-60903		
18	Fan, PCI	F1477-60938		
19	Strap, base/upper (metalized)	F1477-60964		
20	Solenoid	F1477-60908		
21	PCA Assy, LED-Button	F1477-60905		
22	Cable, IDE 1 (long)	F1477-60929		Yes
23	Cable, IDE 2 (short)	F1477-60937		Yes
24	Cable, Audio 1 (short gray - RGGL)	F1477-60927		Yes
24	Cable, Audio 1 (short orange - RGLG)	F1477-60940		Yes
25	Cable, Audio 2 (long)	F1477-60928		Yes
26	Cable, SCSI	F1477-60933		Yes
27	Cable, PCI (120 pin)	F1477-60932		
28	Cable Clamp, PCI Assy	F1477-60962		
29	Cable Clamp, Mech Assy	F1477-60963		
30	Shield, Cable Protection	F1477-60939		
31	Bracket, Dock Release	F1477-60961		
32	Lever, Dock Release	F1477-60926		
33	Housing, Lower Sys	F1477-60922		
34	PCA, Electronics	F1477-60901		
35	Socket, PCMCIA	F1477-60907		

	Description	Part Number	Exchange Part Number	User Repl.
36	Foot, rubber	F1477-60918		Yes
37	Housing, Upper Sys	F1477-60923		
38	Scr-M3.0x0.5+5P-NI	F1477-60946		
39	Scr-4-4OUNC-2A+2B	F1477-60951		
40	Strap, cable	F1477-60965		Yes
41	Scr-plastic	F1477-60952		Yes
42	Module Bay Adapter, OB7100 module	F1445-60901		Yes
42	Module Bay Adapter, OB4100 module	F1468-60901		Yes
42	Module Bay Adapter, OB2100 module	F1585-60901		Yes
43	Scr-M2.0x0.4+12P-ZK	F1477-60943		

Table 4-2. Docking System Power Cables

HP Part Number	Country
8120-2104	Switzerland
8120-2956	Denmark
8120-4211	South Africa
8120-1751	U.S.A.
8120-1351	U. K.
8120-1689	Europe
8120-1369	Australia
8120-8373	Republic of China

Table 4-3. Docking System Accessories

Model Number	Description
F1454A	60-watt AC adapter
F1445A	Docking bay module adapter for 7100
F1468A	Docking bay module adapter for 4100
F1585A	Docking bay module adapter for 2100/3100

- 1. Product Information**
- 2. Removal and Replacement**
- 3. Troubleshooting and Diagnostics**
- 4. Replaceable Parts**